

# Quick Start Guide

## 64-Port 100G Top-of-Rack Switch

AS7816-64X



www.edge-core.com

### Package Contents

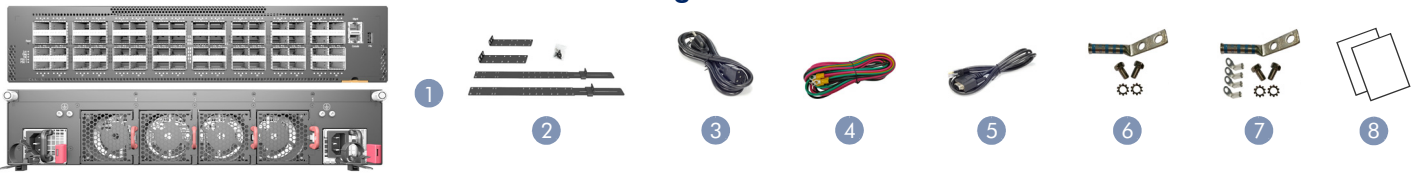

1. 100G Top-of-Rack Switch AS7816-64X
2. Rack mounting kit—2 front-post brackets, 2 rear-post brackets, 20 screws, and 2 ear-locking screws
3. AC power cord
4. DC power cable included with 48VDC PSU only (optional)
5. Console cable—RJ-45 to DB-9
6. Grounding kit—One grounding lug, 2 M5 screws and 2 washers (For AC PSU)
7. Grounding kit—One grounding lug, 4 ring lugs, 2 M5 screws and 2 washers (For DC PSU)
8. Documentation—*Quick Start Guide* (this document) and *Safety and Regulatory Information*



**Caution:** The switch includes plug-in power supply (PSU) and fan tray modules that are installed into its chassis. All installed modules must have a matching airflow direction. That is, if the installed power modules have a front-to-back (F2B) airflow direction, all the installed fan tray modules must also have a F2B airflow direction.

**Attention:** Le commutateur comprend des modules d'alimentation et de bac de ventilateurs installés sur son châssis. Tous les modules installés doivent avoir une direction de circulation d'air correspondante. C'est-à-dire que tous les modules doivent avoir la même direction de circulation d'air: avant vers arrière (F2B), ou arrière vers avant (B2F).



**Note:** The switch has the Open Network Install Environment (ONIE) software installer preloaded on the switch, but no switch software image. Information about compatible switch software can be found at [www.edge-core.com](http://www.edge-core.com).



**Note:** The switch drawings in this document are for illustration only and may not match your particular switch model.



**Caution:** Installing the switch in a rack requires two people. One person should position the switch in the rack, while the other person secures it using the rack screws.

**Attention:** Deux personnes sont nécessaires pour installer un commutateur dans un bâti: La première personne va positionner le commutateur dans le bâti, la seconde va le fixer avec des vis de montage.

## 1 Attach the Brackets

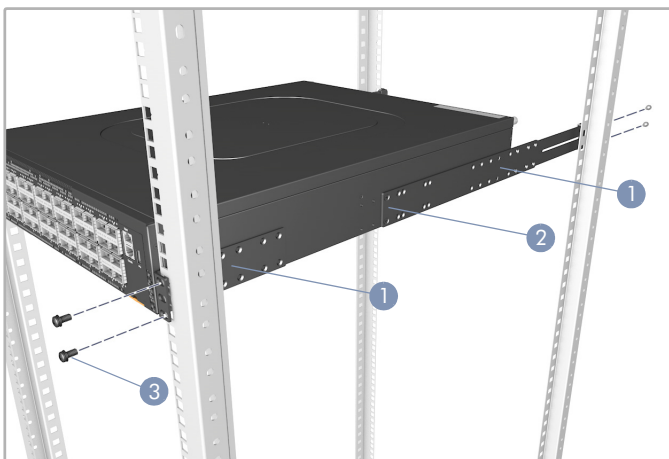

1. Attach each of the front- and rear-post brackets to the switch using four of the included bracket screws.
2. Use an additional two screws to secure each of the rear-post brackets at the mid-point on the sides of the switch.
3. Use the screws and cage nuts supplied with the rack to secure the switch in the rack.

## 2 Adjust Rear-Post Bracket Ears

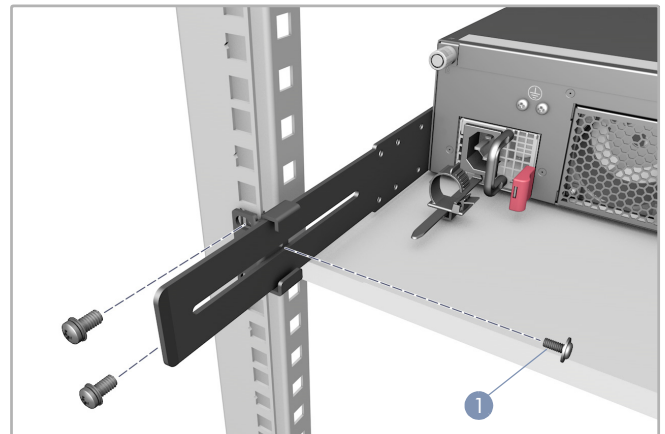

1. Lock the position of the rear-post bracket ears using the included position-locking screws.

You can also adjust the rear-post bracket ears to fit different rack depths from 56 cm to 75 cm.

## 3 Ground the Switch

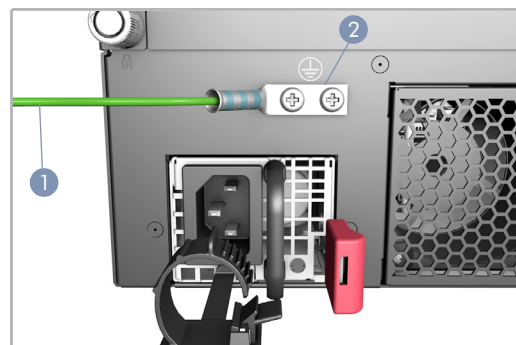

1. Ensure the rack is properly grounded and in compliance with ETSI ETS 300 253. Verify that there is a good electrical connection to the grounding point on the rack (no paint or isolating surface treatment).



\* 1 5 0 2 0 0 0 2 0 1 2 A R 0 4 \*

- Attach a #10 AWG grounding wire (not included) to the grounding point on the switch rear panel. Then connect the other end of the wire to rack ground.



**Caution:** The earth connection must not be removed unless all supply connections have been disconnected.

**Attention:** Le raccordement à la terre ne doit pas être retiré sauf si toutes les connexions d'alimentation ont été débranchées.

#### 4 Connect Power

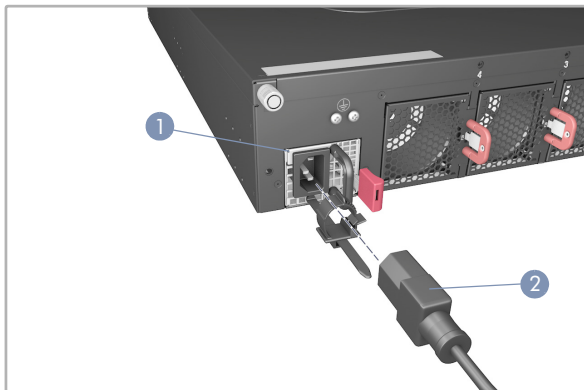

- Install one or two AC or DC PSUs in the switch.

The switch supports up to two PSUs that must have the same matching airflow direction as the installed fan trays.

- Connect an external AC or DC power source to the PSUs.



**Caution:** Use a UL/IEC/EN 60950-1 certified power supply to connect to a DC converter, and a #10 AWG (for -36 VDC to -72 VDC PSU) wire to connect to a DC PSU.

**Attention:** Utilisez une alimentation certifiée UL/IEC/EN 60950-1 pour le connecter à un convertisseur CC et un câble AWG #10 (pour -36 VDC à -72 VDC) pour vous connecter à une alimentation CC.

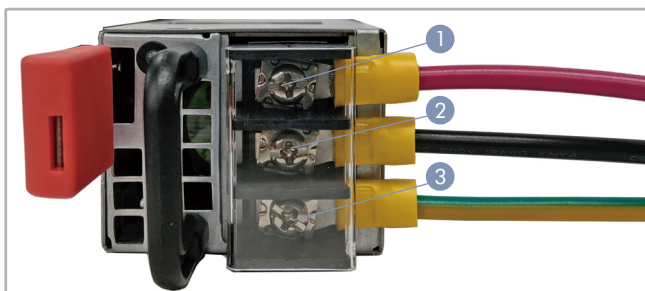

- Connect the RTN return. (red wire).
- Connect the -36 – -72 VDC (black wire).
- Connect the Chassis Ground (yellow-green wire).

#### 5 Verify Switch Operation

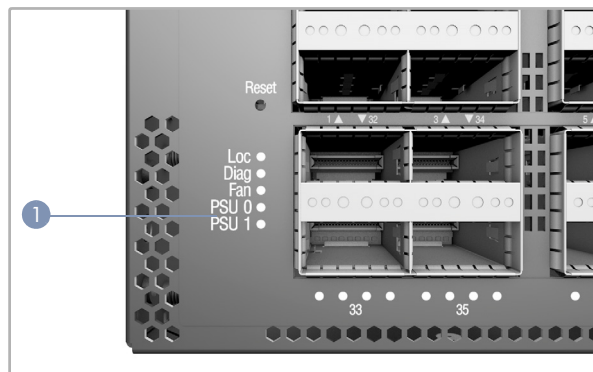

- Verify basic switch operation by checking the system LEDs.

When operating normally, the PSU1/PSU2, Diag, and Fan LEDs should all be on green.

#### 6 Perform Initial System Boot

- If the network operating system (NOS) installer is located on a network server, first connect the RJ-45 Management (Mgmt) port to the network using 100-ohm Category 5, 5e or better twisted-pair cable. (Not required if the NOS installer is located on attached storage.)
- Boot the switch. Wait for the ONIE software to locate and execute the NOS installer, and then wait for the installer to load the NOS software image.

Subsequent switch boots will bypass ONIE and directly run the NOS software.



**Note:** For switches with ONIE software pre-loaded, refer to the network operating system (NOS) installer and NOS documentation for details on software options and set up for ONIE.

#### 7 Connect Network Cables

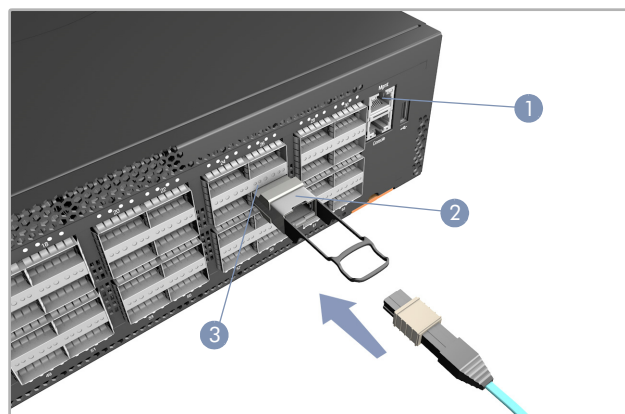

- For the RJ-45 Management port, connect 100-ohm Category 5, 5e or better twisted-pair cable.
- Connect DAC cables to the QSF28 slots. Or first install QSF28 transceivers and then connect fiber optic cabling to the transceiver ports.

The following transceivers are supported:

- 100GBASE-CR4, AOC, SR4, LR4, and PSM4
- 40GBASE-CR4, SR4, and LR4

3. As connections are made, check the port status LEDs to be sure the links are valid.

Each QSFP28 port has four LEDs that indicate valid links in the following modes:

- 1 LED Blue — 100 Gbps mode
- 1 LED Orange — 40 Gbps mode
- 1-4 LEDs White — 25 Gbps breakout mode (four lanes)
- 1-4 LEDs Green — 10 Gbps breakout mode (four lanes)
- 1 and 3 LED Magenta – 50 Gbps breakout mode (two lanes)

## Power and Battery Safety



**Warning:** If your switch uses a lithium battery, do not attempt to replace the battery yourself. Return the switch to the manufacturer for battery replacement.

**Avertissement:** Si votre commutateur utilise une batterie au lithium, n'essayez pas de la remplacer vous-même. Renvoyez le commutateur au fabricant pour le remplacement de la batterie.



If the switch contains lithium batteries that are encased in a sealed chassis, do not attempt to open the sealed chassis under any circumstances.

Si le commutateur contient des batteries au lithium enfermées dans un châssis scellé, n'essayez en aucun cas d'ouvrir le châssis scellé.



Risk of explosion if the battery is replaced by an incorrect type. Dispose of used batteries according to the instructions.

Risque d'explosion si la batterie est remplacée par un type incorrect. Éliminez les piles usagées conformément aux instructions.



**Caution - Risk of Electrical Shock:** To disconnect power, remove all power cords from the unit.



**Attention - Risque de Choc Électrique:** Pour débrancher, l'alimentation électrique, veuillez assurer tous les câbles d'alimentation sont retirés de l'unité.



注意 - 感電の危：電源を切る場合は、電源コートを本装置から抜いてください。

注意 - 有觸電的危險：如要切斷電源，請將全部電源線都從機器上拔掉

注意 - 有觸電的危險：如要切斷電源，請將全部電源線都從機器上拔掉

## Hardware Specifications

### Switch Chassis

Size (WxDxH)	438.4 x 580 x 87.7 mm (17.26 x 22.83 x 3.45 in.)
Weight	14.11 kg (31.1 lb), with two installed PSUs
Temperature	Operating: 0° C to 45° C (32° F to 113° F) Storage: -40° C to 70° C (-40° F to 158° F)
Humidity	Operating: 5% to 95% (non-condensing)
Power Consumption	850 Watts maximum

### PSUs

AC Power Rating	100-240Vac , 50-60Hz, 12-6A, 850 Watts
DC Power Rating	-36 – -72 VDC, 28–14 A, 850 Watts

### Regulatory Compliances

Emissions	EN 55032:2015+AC:2016, Class A EN 61000-3-2:2014, Class A EN 61000-3-3:2013 47 CFR FCC Part 15:2017, Subpart B, Class A CE Mark
Immunity	EN 55024:2010+A1:2015 IEC 61000-4-2/3/4/5/6/8/11
Safety	UL (CSA 22.2 No 60950-1 & 62368-1; UL60950-1 & 62368-1) CB (IEC/EN60950-1 & 62368-1) NOM CCC